

PARÇA KODU PART CODE	PARÇA ADI PART NAME	s ÖLÇÜSÜ s MEASURE	w ÖLÇÜSÜ w MEASURE	h ÖLÇÜSÜ h MEASURE	Malzeme Material	Kaplama / Coating		
						SN	AG	Nİ
TŞB 2555 DP	TOPRAKLAMA KLEMENSİ Ø4.3 =DP=	0.5±0.03	3.5±0.2	3.4 +0.2	(CuZn30) Pirinç / Brass	-	-	-
TŞB 2555 DPK	TOPRAKLAMA KLEMENSİ Ø4.3 =DPK=	0.5±0.03	3.5±0.2	3.4 +0.2	(CuZn30) Pirinç + Kalay / Brass + Sn	+	-	-
TŞB 2555 RP	TOPRAKLAMA KLEMENSİ Ø4.3 =RP=	0.5±0.03	3.5±0.2	3.4 +0.2	(CuZn30) Pirinç / Brass	-	-	-
TŞB 2555 RPK	TOPRAKLAMA KLEMENSİ Ø4.3 =RPK=	0.5±0.03	3.5±0.2	3.4 +0.2	(CuZn30) Pirinç + Kalay / Brass + Sn	+	-	-
TŞB 2555.80 DP	TOPRAKLAMA KLEMENSİ Ø4.3 (0.80) =DP=	0.8±0.03	3.6±0.2	3.8±0.2	(CuZn30) Pirinç / Brass	-	-	-
TŞB 2555.80 DPK	TOPRAKLAMA KLEMENSİ Ø4.3 (0.80) =DPK=	0.8±0.03	3.6±0.2	3.8±0.2	(CuZn30) Pirinç + Kalay / Brass + Sn	+	-	-
TŞB 2555.80 RP	TOPRAKLAMA KLEMENSİ Ø4.3 (0.80) =RP=	0.8±0.03	3.6±0.2	3.8±0.2	(CuZn30) Pirinç / Brass	-	-	-
TŞB 2555.80 RPK	TOPRAKLAMA KLEMENSİ Ø4.3 (0.80) =RPK=	0.8±0.03	3.6±0.2	3.8±0.2	(CuZn30) Pirinç + Kalay / Brass + Sn	+	-	-

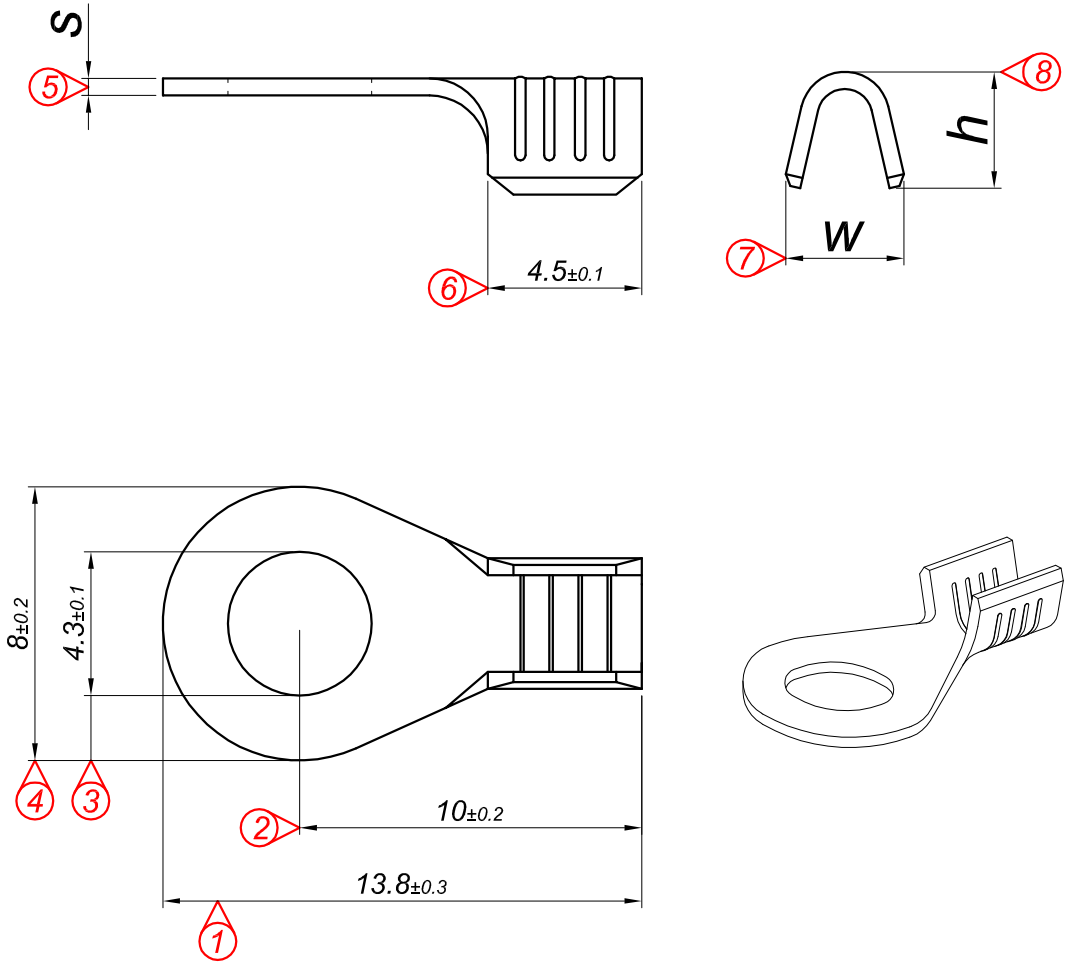

### Kablo Kesiti

Wire Section : 0.50 - 1 mm<sup>2</sup>

Resmin Üzerinden Ölçü Almayınız

Don't use the drawing for measuring purpose

Tarih / Date	22.08.2013	İmza /Signature	Ölçek / Scale			
Çizen / Desing	M.Yağcı		5 / 1	01	Teknik Resimde bulunan tabloya 0.80 kalınlık eklenmiş, tablo yeniden düzenlenmiştir.	18.11.2014
Onay / Approval	S.Gölcük			No	Değişiklik / Revision	Tarih/Date
	Parça Adı: Part Name	TOPRAKLAMA KLEMENSİ Ø4.3			Parça Kodu: Part Code	TŞB 2555

